



# SOUTH AFRICAN NOTICE TO MARINERS

FEBRUARY 2002 EDITION

PUBLISHED MONTHLY  
BY THE  
HYDROGRAPHIC OFFICE  
CAPE TOWN

## CONTENTS

- I Explanatory Notes and Index
- II SAN Notices to Mariners. Updates to Standard Navigational Charts
- III SAN Charts and SAN HO Publications - New Charts / Editions
- IV Corrections to SAN HO Publications
- V Corrections to SA List of Lights and Radio Services
- VI Reprints of Radio Navigational Warnings

## IMPORTANT

Mariners are requested to inform the Hydrographer, Private Bag X1, Tokai 7966, immediately of the discovery of new dangers, or changes or defects in aids to navigation and of shortcomings in South African charts or publications. Copies of form HO-16, which is a convenient form on which to send in a report, may be obtained gratis from any Official Chart Agent or the reproduction at the end of Section VI of the monthly edition of Notices to Mariners.

In addition to postal methods, the following additional communication facilities are available :

Notices to Mariners Web site :	Web :	<a href="http://hydro.imt.za/hydronet/Ho/">http://hydro.imt.za/hydronet/Ho/</a>
Urgent navigational information :	Fax :	021 787 2228
	Phone :	021 787 2445
Other navigational information :	Phone :	021 787 2444
	E-mail :	<a href="mailto:hydrosan@iafrica.co.za">hydrosan@iafrica.co.za</a>
General information :	Phone :	021 787 2408

L.D. Reeder, Captain  
Hydrographer, SA Navy  
NAVAREA VII Co-ordinator

INDEX OF CHARTS AND PUBLICATIONS AFFECTED

---

SAN Charts	Notices	Pages
75(INT 2630)	26(T)	2
80(INT 2680)	27(T)	2
119	27(T)	2
125	28	2
126	28	2
127	29	2
150	27(T)	2
1002	26(T)	2
1016	27(T)	2
1025	55/01	1
SC 4	27(T)	2

SAN Publications	Notices	Pages
Catalogue and Indexes of SAN Charts and other Publications SAN -3 (2000 Edition)	30	6
South African Sailing Directions Volume II SAN HO-22 (1995 Edition)	31	6
Cumulative List of South African Notices to Mariners 2002	32	7
Annual Summary of South African Notices to Mariners 2002	33	7

---

## I

### Spheroid / GPS Positions

All positions quoted in these Notices are referred to Clarke 1880 (Mod) Spheroid unless otherwise stated. On chart scales of 1: 100 000 and smaller, positions from GPS receivers set to WGS 84 may be plotted directly on these charts. Mariners are warned that insertion of Clarke 1880 (or other) positions on Automatic Plotters which are set to WGS 84 Spheroid can result in inaccurate navigation practices.

### Temporary and Preliminary Notices

These are indicated by (T) or (P) after the notice number. These are printed on one side of the paper in order that they may be cut and filed and are placed at the end of Section II. Information from these notices is not included on charts before issue; charts should be updated in pencil on receipt.

### Permanent Notices

Permanent corrections in Section II are marked by a star adjacent to the notice number to indicate that the notice is based on original information. Periodic lists of permanent corrections pertaining to affected navigational charts and publications are published annually and copies may be obtained from the Hydrographic Office or through a Chart Agent.

### Chart Corrections

Further details are contained in NP100 The Mariner's Handbook which should be consulted for the correct procedures of filing, inserting and noting all types of corrections on nautical charts and other hydrographic publications. The Handbook may be obtained from Admiralty Chart Agents in Cape Town and Durban. Consult SAN HO-6 for Symbols and Abbreviations used on SAN Charts and NP735 for an illustrated explanation of the IALA Maritime Buoyage System.

### Provision of Notices to Mariners

These Notices are gratis and may be obtained on request from the Hydrographic Office or through the approved Chart Agents. Additional copies required of "block" chart corrections can also be obtained through the above procedure.

### Radio Navigational Warnings

See Note at the start of Section III

## GUIDANCE NOTES FOR VIEWING AND PRINTING NOTICES USING ADOBE ACROBAT

For optimum results when viewing and printing material from the PDF digital files please note the following:

The minimum specification is a 486 PC with Windows 3.1 and 4MB of RAM.

When printing data from the files, ensure the Fit to Page icon in the Adobe Acrobat print menu is switched off before printing. Otherwise large text pages will be compressed, or large size Blocks may not fit the chart.

If printing text or monochrome NM Blocks, the minimum specification is an Inkjet or good quality Laser Postscript printer with at least 6 MB of memory. (NB. If using a Postscript printer, ensure the Postscript printer driver is installed).

For printing Colour NM Blocks the minimum specification of printer is a good quality Ink Jet/Laser printer with 300 dpi resolution or greater.

If using certain types of Ink Jet printer ensure the setting is set to Dithered screening not Pattern screening.

Printed colour copies should be compared with the colour image on screen to ensure that all the colours have reproduced correctly. Printer property resolution and ink density may need to be increased or adjusted to obtain the best results.

Ensure the Colour Ink Cartridge is in accordance with the printer manufacturers specifications. Minimum paper specification for printing Colour NM Blocks is International paper size A4, thickness/weight 80 gsm paper. (The same paper as used for NM Blocks in the NM Weekly). NB. (Ensure the paper quality is in accordance with the Printer manufacturers specifications).

**The Hydrographer does not accept any liability for the display and printing of these digital Notices to Mariners on the users equipment.**

II

ERRATUM

1. All Charts SAN 1025, issued after March 2001, may have had the under mentioned Notice to Mariners incorrectly applied. Notice to Mariners 55/01 is hereby repeated in order that mariners may apply the correct limits of the Aquaculture Area.

55/01 SOUTH AFRICA. Algoa Bay - Port Elizabeth - Aquaculture Areas.

- |    |                   |                                                                                   |             |              |                              |
|----|-------------------|-----------------------------------------------------------------------------------|-------------|--------------|------------------------------|
| 1. | Insert :          |  | enclosed by | TTTT         | joining following positions  |
| 2. | Clarke 1880 (Mod) | a.                                                                                |             | 33°56'.427 S | 025°36'.992 E.               |
|    |                   | b.                                                                                |             | 33°56'.423 S | 025°37'.813 E.               |
|    |                   | c.                                                                                |             | 33°56'.697 S | 025°37'.815 E.               |
|    |                   | d.                                                                                |             | 33°57'.194 S | 025°38'.192 E.               |
|    |                   | e.                                                                                |             | 33°57'.282 S | 025°37'.598 E.               |
|    |                   | f.                                                                                |             | 33°56'.996 S | 025°36'.970 E.               |
|    |                   | g.                                                                                |             | 33°56'.427 S | 025°36'.992 E. (closed area) |
| 3. | WGS 84            | a.                                                                                |             | 33°56'.434 S | 025°36'.966 E.               |
|    |                   | b.                                                                                |             | 33°56'.430 S | 025°37'.786 E.               |
|    |                   | c.                                                                                |             | 33°56'.704 S | 025°37'.789 E.               |
|    |                   | d.                                                                                |             | 33°57'.201 S | 025°38'.166 E.               |
|    |                   | e.                                                                                |             | 33°57'.289 S | 025°37'.572 E.               |
|    |                   | f.                                                                                |             | 33°57'.003 S | 025°36'.920 E.               |
|    |                   | g.                                                                                |             | 33°56'.434 S | 025°36'.966 E. (closed area) |
| 4. | Clarke 1880 (Mod) | a.                                                                                |             | N. Border    | 025°38'00" E.                |
|    |                   | b.                                                                                |             | 33°57'12" S  | 025°38'12" E.                |
|    |                   | c.                                                                                |             | 33°57'18" S  | 025°37'36" E.                |
|    |                   | d.                                                                                |             | 33°57'00" S  | 025°37'00" E.                |
|    |                   | e.                                                                                |             | N. Border    | 025°37'00" E. (closed area)  |

SAN Charts :                    1024 (INT 7531) (1, 3)                    (133/00)  
                                          1025                    (1, 2)                    (NE)  
                                          SC 9 (Port Elizabeth Inset (1, 4)                    (133/00)

Source :                    Port Captain, Port Elizabeth

MISCELLANEOUS:

1. Mariners are advised that South African Notices to Mariners is available in PDF format on the internet at  
 Website : <http://hydro.int.za/hydronet/Ho/>.

2. Mariners attention is invited to the fact that the Hydrographic Office E-Mail number hydrosan@iafrica.co.za is only manned during office hours, Mondays to Friday, between the hours of 0600 UTC and 1400 UTC. Only matters of a routine nature must be forwarded by this method.

SA NAVY SAN CHARTS INDEPENDENTLY WITHDRAWN

SAN Chart Number	Main Title
102	Southern Africa - West Coast, Hoarusib River to/na Sand Table Hill.
105	Southern Africa - West Coast, Ugab River to/na Sierra Point.
109	Sout West Africa, South Rocks to/na Spencer Bay.

Charts covering the Namibian coastline are covered by the 1 : 300 000 Int Series.

II

\*26(T) NAMIBIA, South Coast - Lüderitz - Diaz Point Fog Signal (Z 5541) - Inoperative.

1. Insert : Inoperative next to Horn 30s in position 26°37'.9 S 015°05'.6 E

SAN Charts 75(INT 2630) (23/01)  
1002(INT 2631) (50/00)

Source : NAMPORT

(SAN 75, 1002)

\*27(T) SOUTH AFRICA, South West Coast - False Bay - Whittle Rock Buoy - (Zf 7389)  
(Df 6140)

1. Buoy off station in position 34°13'.245 S 018°34'.239 E

SAN Charts 80(INT 2680) (68/01)  
119 (67/01)  
150 (53/01)  
1016 (53/01)  
SC 4 (51/01)

Source Naval Harbour Master

(SAN 80, 119, 150, 1016, SC 4)

\*28 SOUTH AFRICA, South Coast - Port Elizabeth - Beacons

1. Delete : Bn ⊙ and colour legends in position a. 33°58'.8 S 025°38'.9 E  
b. 33°59'.8 S 025°40'.0 E  
c. 33°59'.4 S 025°40'.6 E

SAN Chart : 125 (a to c) (133/00)  
126 (c) (103/01)

Source : Hydrographer

(SAN 125, 126)

\*29 SOUTH AFRICA, South East Coast - Rietpunt - Radio Mast

1. Delete : Radio Mast Symbol and legend  
(Red Lts) in approximate position 33°33'.0 S 027°01'.7 E

SAN Chart : 127 (37/00)

Source : Litton Marine Systems BV

(SAN 127)

II

TEMPORARY NOTICES AND PRELIMINARY NOTICES

In force 25 February 2002

TEMPORARY NOTICES

1999 Series

74(T)	RSA	East Coast	Current Meter laid.
93(T)	Namibia	South Coast	Buoy and Current Meters laid.

2000 Series

59(T)	RSA	South Coast	Current Meter - Buoy laid.
75(T)	RSA	South Coast	Current Meters laid.
88(T)	Namibia	South Coast	Current Meters laid.

2001 Series

82(T)	Namibia	Walvis Bay	Unlit vessel at anchor.
86(T)	RSA	St Helenabaai	Telemetry Marker Buoy laid.
94(T)	Namibia	Lüderitz	Bell Buoy unlit.
95(T)	Namibia	Lüderitz	Tiger Reef Buoy missing.
102(T)	RSA	SW Coast	Arniston Light Character changed.
107(T)	RSA	Simon's Bay	East Breakwater Light unlit.
109(T)	Namibia	Walvis Bay	Wave Meter Buoys laid.

2002 Series

26(T)	Namibia	Lüderitz	Diaz Point Fog Signal inoperative.
27(T)	RSA	False Bay	Whittle Rock Buoy off station.

PRELIMINARY NOTICES

Nil prior to these Notices.

2001 Series

61(P)	RSA	South & East Coasts	Underwater cable laying.
81(P)	RSA	South & West Coasts	Underwater cable laying.
113(P)	RSA	East Coast, Durban	Vessel Traffic Services.

IIA

LIST OF TEMPORARY AND PRELIMINARY NOTICES TO MARINERS ISSUED  
BY THE MOZAMBIQUE INSTITUTE OF HYDROGRAPHY AND NAVIGATION  
(INAHINA) IN FORCE

1998 Series

2MOZ(T)	Port of Beira -	Lit Waverider Buoy	Laid.
3MOZ(P)	Port of Beira -	White Spar Buoy	Laid.

1999 Series

12MOZ(P)/99	Port of Quelimane -	Depths	Changed.
-------------	---------------------	--------	----------

2000 Series

08MOZ(T)/00	East Coast -	Barra Falsa Light (D6536)	Temp. unlit.
09MOZ(T)/00	East Coast -	Ponta Zavora Light (D6528)	Temp. unlit.
10MOZ(T)/00	South Coast -	Boa Paz Light (D6524)	Temp. unlit.

2001 Series

01MOZ(T)/01	Port of Maputo -	Buoy No. 2N	Temp. unlit.
03MOZ(T)/01	Port of Beira -	Buoy No. 10	Temp. unlit.
07MOZ(T)/01	Port of Beira -	Buoy No. T	Out of position.
08MOZ(T)/01	Port of Beira -	Buoy No. 7	Repositioned.
15MOZ(T)/01	North Coast	Ilha Epidendron Light (D6582)	Temp. unlit.
17MOZ(T)/01	Porto de Maputo	Beacon Esparcelado da Catemby (D6508)	Temp. unlit.

2002 Series

02MOZ(T)/02	Porto de Quelimane	Buoy No P	Temp. unlit.
03MOZ(T)/02	Porto de Quelimane	Buoy No 1	Out of position.
04MOZ(P)/02	Baía de Maputo	Underwater Cable Laying.	
05MOZ(P)/02	Vilanculos	Underwater Cable Laying.	
06MOZ(P)/02	Porto da Beira	Underwater Cable Laying	

## IIA

### 04MOZ(P) MOZAMBIQUE - East Coast - Baía de Maputo - Submarine Cable.

1. Fibre optic cable laying and associated operations is taking place in the approaches to Maputo for the Mozambique Domestic Cable Systems for Telecomunicaçõesde Moçambique (TDM).

2. The cable will be laid via the following approximate positions:

a. 25°56'.02 S	033°37'.77 E	b. 25°55'.95 S	032°39'.03 E
c. 25°54'.50 S	032°41'.07 E	d. 25°53'.50 S	032°48'.20 E
e. 25°48'.03 S	032°58'.35 E.		

3. Vessels are requested to give the cable laying vessel a wide berth (at least 2 miles) and avoid anchoring and trawling in the vicinity of the cable.

4. Originally issued as NAVAREA VII message 017 of 2002.

Charts : Moz. 439, 440, BA 644, 646.  
Source : Beiracable LDA

### 05MOZ(P) MOZAMBIQUE - East Coast - Vilanculos - Submarine Cable.

1. Fibre optic cable laying and associated operations is taking place in the approaches to Vilanculos for the Mozambique Domestic Cable Systems for Telecomunicaçõesde Moçambique (TDM).

2. The cable will be laid via the following approximate positions:

#### Segment D

a. 22°00'.42 S	035°19'.34 E	b. 22°00'.44 S	035°25'.49 E
c. 22°00'.45 S	035°26'.29 E	d. 22°00'.37 S	035°31'.97 E

#### Segment C

a. 22°00'.42 S	035°19'.34 E	b. 22°04'.29 S	035°22'.60 E
c. 22°05'.41 S	035°27'.29 E	d. 22°05'.43 S	035°32'.18 E

3. Vessels are requested to give the cable laying vessel a wide berth (at least 2 miles) and avoid anchoring and trawling in the vicinity of the cable.

4. Originally issued as NAVAREA VII message 011 of 2002.

Charts : Moz. 423, 436, BA 2932.  
Source : Beiracable LDA

### 06MOZ(P) MOZAMBIQUE - East Coast - Porto da Beira - Submarine Cable.

1. Fibre optic cable laying and associated operations is taking place in the approaches to Beira for the Mozambique Domestic Cable Systems for Telecomunicaçõesde Moçambique (TDM).

2. The cable will be laid via the following approximate positions:

a. 19°50'.38 S	034°54'.24 E	b. 19°50'.50 S	034°56'.61 E
c. 19°50'.54 S	035°03'.63 E	d. 19°52'.82 S	035°10'.43 E

3. Vessels are requested to give the cable laying vessel a wide berth (at least 2 miles) and avoid anchoring and trawling in the vicinity of the cable.

4. Originally issued as NAVAREA VII message 011 of 2002.

Charts : Moz. 417, 418, 488, BA 1003, 2932.  
Source : Beiracable LDA

### III

## SAN CHARTS AND SAN HO PUBLICATIONS - NEW CHARTS / EDITIONS

SOUTH AFRICAN SAILING DIRECTIONS Volume II SAN HO-22 is currently undergoing a major revision and upgrading. The new edition will be available mid-2002.

### IV

## CORRECTIONS TO SAN PUBLICATIONS

- 30 CATALOGUE AND INDEXES OF SAN CHARTS AND OTHER PUBLICATIONS  
SAN HO-3 (2000 EDITION)
1. Page 2 : INDEX OF NAVIGATIONAL CHARTS  
Delete all references to SAN 102, SAN 105 and SAN 109. Charts permanently withdrawn.
  2. Page 10 : Delete limits of Charts SAN 102 & SAN 105 Charts permanently withdrawn.
  3. Page 11 : 1 : 150 000 NATIONAL SERIES  
Delete Charts SAN 102 & SAN 105 Charts permanently withdrawn.
  4. Page 12 : Delete limits of Chart SAN 109 Chart permanently withdrawn.
  5. Page 13 : 1 : 150 000 NATIONAL SERIES  
Delete Chart SAN 109 Chart permanently withdrawn.
  6. Page 32 : SAN CHART FOLIO LIST No 1  
Delete Charts SAN 102, SAN 105 & SAN 109 Charts permanently withdrawn.
- 31 SOUTH AFRICAN SAILING DIRECTIONS VOLUME II SAN HO-22 (1995 Edition)
1. Page viii CHART INDEX : KUNENE RIVER TO CAPE AGULHAS  
Delete limits (Green Blocks) of Charts SAN 100 to SAN 112.
  2. Page 1-4 CHART INDEX : KUNENE RIVER TO WALVIS BAY  
Delete limits (Green Blocks) of Charts SAN 100 to SAN 106.
  3. Page 1-13 line 1 Delete Chart SAN 102 Chart permanently withdrawn.
  4. Page 1-21 line 1 Delete Chart SAN 105 Chart permanently withdrawn.
  5. Page 1-24 line 1 Delete Chart SAN 105 Chart permanently withdrawn.
  6. Page 2-4 CHART INDEX : WALVIS BAY TO LÜDERITZ  
Delete limits (Green Blocks) of Charts SAN 108 to SAN 110.
  7. Page 2-5 line 1 Delete Chart SAN 109 Chart permanently withdrawn.
  8. Page 2-11 line 1 Delete Chart SAN 109 Chart permanently withdrawn.
  9. Page 3-4 CHART INDEX : LÜDERITZ TO PORT NOLLOTH  
Delete limits (Green Blocks) of Charts SAN 110 to SAN 112.



## VI

### NAVAREA VII and Coastal Navigational Warnings Bulletin in force as at 25 February 2002

See NM 3/2002. Broadcast Warnings are available at Port Offices and remain valid until cancelled or until superseded by this and/or other broadcast bulletins.

#### NAVAREA VII MESSAGES

Nil Prior to these Messages.

##### 2002 Series

011	S Indian, Mozambique Channel	Fibre Optic Cable laid.
017	S Indian, Mozambique, Baia de Maputo	Fibre Optic Cable laid.
019	S Atlantic, NE Sector, Angola	Pride of Angola.

#### COASTAL NAVIGATIONAL WARNINGS

Nil Prior to these Messages

##### 2002 Series

014	Namibia / RSA	Rig List.
031	RSA West Coast	Seismic Surveying by MV Western Trident.
032	RSA West Coast	Seismic Surveying by MV Geo Explorer.
055	RSA False Bay	Whittle Rock Buoy out of position.
056	Namibia Lüderitz	Diaz Point Fog Signal inoperative.
069	RSA East Coast	Cooper Light DGPS inoperative.
081	Namibia / RSA	Marine Mining Vessels.
087	RSA East Coast	Bird Island Mainlight unlit.
088	RSA South West Coast	Gunnery exercises in progress.
089	RSA Simon's Bay	Missile shaped target laid.
090	RSA South West Coast	Gunnery exercises in progress.
091	RSA False Bay	Gunnery exercises in progress.

#### ANNEX A

##### USA Government Special Warning in force 18 December 2001

##### SPECIAL WARNING NUMBER 120 WORLDWIDE

1. Due to recent events in the Middle East and the American Homeland, U.S. Forces worldwide are operating at a heightened state of readiness and taking additional defensive precautions against terrorists and other potential threats. Consequently, all aircraft, surface vessels, and sub-surface vessels approaching U.S. Forces are requested to maintain radio contact with U.S. Forces on bridge-to-bridge channel 16, international air distress (121.5 Mhz VHF) or MILAIR distress (243.0 Mhz UHF).

2.. U.S. Forces will exercise appropriate measures in self-defence if warranted by the circumstances. Aircraft, surface vessels, and sub-surface vessels approaching U.S. Forces will, by making prior contacts as described above, help make their intentions clear and avoid unnecessary initiation of such defensive measures.

3. U.S. Forces, especially when operating in confined waters, shall remain mindful of navigational considerations of aircraft, surface vessels, and sub-surface vessels in their immediate vicinity.

4. Nothing in the Special Warning is intended to impede or otherwise interfere with the freedom of navigation or overflight of any vessel or aircraft, or to limit or expand the inherent self-defence rights of U.S. Forces. This Special Warning is published solely to advise of the heightened state of readiness of U.S. Forces and to request that radio contact be maintained as described above. :Issued 16 Nov 2001)

H0-16

Ship's Name :

Consec No:

Date and Year:

## HYDROGRAPHIC NOTE

General Locality :

Subject :

Approx Position :

Latitude:

Longitude:

SAN chart(s) affected :

Publications affected :

(quote Volume, Supplement and Page)

Full details :

A replacement copy of Chart No ..... is required.

Navigating Officer or Observer:

Captain or Master:

Ship (or address):

If Merchant Vessel add Line or :  
Company with Head Office address

Note: An acknowledgment of receipt will be sent and the information then used to the best advantage which may mean immediate action or inclusion in a revision in due course.

When a Notice to Mariners is issued the sender's ship or name is quoted as authority unless as sometimes happens the information is also received in a foreign Notice to Mariners.

### Instructions for the forwarding information for South African charts and hydrographic publications

1. Mariners are requested to notify the Hydrographer of the South African Navy, Private Bag X1, Tokai, 7966, or by Fax 021-787 2228, or e-mail [hydrosan@iafrica.co.za](mailto:hydrosan@iafrica.co.za) when new or suspected dangers to navigation are discovered, changes observed in aids to navigation, or corrections to publications seem to be necessary.
2. Copies of this Form may be obtained gratis from the Hydrographer, Private Bag X1, Tokai, 7966 or the Chart Agents listed in Annual Summary of South African Notices to Mariners.
3. When a position is defined by sextant angles or bearing (true or magnetic north being specified) more than two should be used in order to provide a check. Any distances observed by radar should be quoted. When however there is a series of fixes along a ship's course, only the method of fixing and the objects used need to be indicated.
4. For positions obtained using GPS equipment the type of receiver and reference spheroid used must be included under Full Details.
5. A tracing from the largest scale chart or a cutting from it may be the best medium for forwarding details, and the alterations and additions should be shown thereon in red. A new copy of the chart will be sent if requested.
6. When soundings are forwarded the method used should be stated. If it is echo sounding, details should be forwarded as in Annual Notice to Mariners No 4. It is important to state whether echo depths are referred to the surface of the sea or to a transmitter at a specified depth below it. Time and date will be necessary to correct sounding for tidal height; and if any correction has already been made details must be given.
7. Reports which cannot be confirmed or are lacking in certain details should not be withheld. Shortcomings should be stressed and any firm expectation of being able to check the information on a succeeding voyage should be mentioned.
8. Reports of shoal soundings, navigation aids out of order, should be made by radio to the nearest coast radio station and addressed to HYDROSAN, CAPE TOWN. These reports should then be followed by documentary evidence on this form accompanied by the relevant echo sounder traces.

**SOUTH AFRICAN NOTICE TO MARINERS  
NO 20 OF 2002**

Former Notice No 20/2001 is cancelled.

**DIFFERENTIAL GLOBAL POSITIONING SYSTEM (DGPS)**

**GENERAL NOTES**

1. The South African Lighthouse Services of PORTNET established a DGPS system at certain lighthouses along the South African Coast in mid 2000, these DGPS Stations are still under trial.

2. Further DGPS stations may be established if the need arises. There will initially be 4 transmitters situated in strategically positioned sites where poor visibility, presence of Vessel Traffic Services and high concentrations of traffic can be expected. They will be in operation at the following old Radio Beacon Stations :

	<i>Beacon</i>	<i>Beacon Listing</i>	<i>Light List number</i>
a.	Cape Columbine	1823	Z5670 (D5810)
b.	Cape Agulhas	1831	Z5980 (D6370)
c.	Cape Recife	1839	Z6100 (D6390)
d.	Cooper Lt. Ho	1857	Z6245 (D6458)

3. These are intended to provide coverage out to a distance of at least 100 nm. All the stations will initially be transmitting on a trial basis. Details will be promulgated by Coastal NavWarning and/or Notice to Mariners.

4. Details of the locations, ranges and transmission characteristics are given in the accompanying table.

5. Such information will be amended as and when necessary as a result of the preliminary trials. Accurate positions of stations will be promulgated when these have been surveyed and the final positions of the station have been accurately established.

6. The service is being provided primarily for the use in monitoring the integrity of the GPS and to enable greater accuracy for marine navigation as a secondary feature.

7. In order to make use of the DGPS corrections, users will require a GPS Receiver which can accept differential corrections data in the RTCM <N>SC 104 format and an Auto Tuning MSK Beacon Receiver, compatible with conventional IALA-standard radio beacon transmissions.

8. These receivers will tune into the strongest available DGPS signal. The receiver should meet the technical standards of the International Telecommunications Union (ITU) for such receivers. A combined Beacon/GPS receiver with combined antennae incorporated can also be used. With a field strength throughout the coverage area designed to be at least 75 micro V per metre, the DGPS corrections will be updated at intervals of not more than 10 seconds.

9. Regular announcements will be made through the normal channels giving further details of the progress of the introduction of the DGPS system.

<i>Station Reference Number</i>	<i>Station Name</i>	<i>DGPS Corrections</i>		<i>Identification No. of</i>		<i>Range in Nautical Miles</i>	<i>Integrity Monitoring</i>	<i>Status</i>	<i>Transmitted Message Types</i>	<i>Station Position</i>
		<i>tx fx (in kHz)</i>	<i>tx rate (in bps)</i>	<i>Reference Station(s)</i>	<i>Transmit Station</i>					
1823	Cape Columbine	310	100	221/241	201	150@ 75µV/m	YES	TRIAL	3, 6,7,9,16	32°49'S 017°51'E
1831	Cape Agulhas	301	100	223/243	203	120@ 75µV/m	YES	TRIAL	3, 6,7,9,16	34°49'S 020°00'E
1839	Cape Recife	291	100	225/245	205	150@ 75µV/m	YES	TRIAL	3, 6,7,9,16	34°01'S 025°42'E
1857	Cooper Lighthouse	292	100	228/248	208	100@ 75µV/m	YES	TRIAL	3, 6,7,9,16	29°56'S 031°00'E

**CORRECTIONS TO BE APPLIED TO POSITIONS OBTAINED FROM GPS SATELLITE RECEIVERS  
(BASED ON THE GLOBAL POSITIONING SYSTEM (WGS84) SPHEROID)  
FOR PLOTTING ON SAN NAUTICAL CHARTS BASED ON THE CLARKE 1880(MOD) SPHEROID.**

**1 : 150 000 AND LARGER SCALE CHARTS**

CHART NUMBER	SHIFTS (m) Latitude	Longitude
SAN 113	-38	69
SAN 114	-33	68
SAN 115	-29	65
SAN 117	-33	65
SAN 118	-19	64
SAN 119	-8	63
SAN 120	-7	60
SAN 121	-7	56
SAN 122	-8	53
SAN 123	-11	50
SAN 124	-11	46
SAN 125	-13	42
SAN 126	-14	40
SAN 127	-16	37
SAN 128	-21	34
SAN 129	-25	31
SAN 130	-30	28
SAN 131	-35	26
SAN 132	-27	23
SAN 133	-47	21
SAN 134	-55	22
SAN 135	-38	24
SAN 150	-10	62
SAN 1001	-82	73
SAN 1002	-53	72
SAN 1009	-16	64
SAN 1010	-15	65
SAN 1011	-15	64
SAN 1013	-11	63
SAN 1014	-11	62
SAN 1016	-9	62
SAN 1020	-11	52
SAN 1021	-12	49
SAN 1022	-12	48
SAN 1025	-14	43
SAN 1027	-20	35
SAN 1029	-37	26
SAN 1030	-39	24
SAN 1031	-39	25
SAN 2003	22	5
SAN 2051	-57	34
SAN 2052	-15	6

**1 : 300 000 AND SMALLER SCALE CHARTS**

Positions obtained from a GPS Receiver can be plotted directly on these charts as the shift is of such a small nature that it is not plottable.

## SOUTH AFRICAN NOTICE TO MARINERS NO 16 OF 2002

Former Notice No 16/2001 is cancelled.

### SOUTH AFRICA, Offshore Underwater Obstructions.

1. Numerous underwater obstructions - abandoned or suspended well heads, anchors and other equipment - are situated on the seabed in areas between the Orange River and Port Alfred.

2. The well heads are constructed of ferrous metal and are up to 4 m long, 4 m wide and extend up to a height of 4.57 m above the sea floor. See diagram on following page.

3. These obstructions do not constitute any hazard to surface vessels but do present a potential threat to the seafloor mining and to the nets of bottom trawlers. These obstructions are shown on charts of the 1: 150 000 and 1: 300 000 series.

#### 4. Wellhead Status :

**A=Abandoned** Wellhead elevation 4.57m above seafloor, 3.66m diameter, except :  
\* Partially recovered (Temporary guide-base remains) : elevation 0.91m.  
\*\* O-A1 only : Wellhead elevation : 2.51m, diameter 1.52m.

**S=Suspended** Wellhead (4.57 m high) remains on seafloor pending future action (e.g. further drilling or production) except :  
\* Suspended wellhead capped casing stub is 2.5 m high.

5. The positions in the following tables are referred to the Clarke 1880 (Mod) Spheroid. The accuracy of the positions are within 3m except for those positions marked with a † which are within 30m of position..

6. This information is supplied by Petroleum Agency SA.

### ABANDONED AND SUSPENDED WELL HEADS

ATLANTIC OCEAN - WEST COAST OF SOUTHERN AFRICA				Name	S.	E.	Status	Name	S.	E.	Status
(In order of increasing Latitude)											
Name	S.	E.									
				Jc-C1	29 44 8.1	31 18 35.3	A	Ga-V1	34 43 1.96	23 25 21.31	A*
				Hb-D1	34 0 50.47	26 11 16.32	A	Ga-C1	34 43 2.71	23 2 56.92	A†
				Hb-P1	34 1 31.58	26 5 16.42	A	D-C1	34 43 48.25	20 49 29.36	A†
Kudu 2	28 29 00.72	14 34 25.97		Ha-F1	34 4 48.15	25 22 20.62	A*	E-B1	34 44 12.01	21 10 0.97	A
Kudu 9A-1	28 32 53.22	14 34 44.87		Hb-H1i	34 9 11.54	25 54 17.45	A†	Gb-M1	34 44 26.47	24 11 54.37	A†
Kudu 3	28 34 54.27	14 35 54.89		Hb-H1	34 9 12	25 54 18	A†	E-II	34 50 9.69	21 45 45.15	A
Kudu 5	28 37 58.25	14 40 29.05		PB-A1	34 9 39.9	23 20 12.13	A†	F-D1	34 51 23.77	22 56 39.12	A
				Hb-G1	34 11 6.32	25 51 34.51	A†	E-S2	34 51 39.4	21 51 20.93	A
				Ha-N1	34 13 38.7	25 40 50.5	A	E-S5	34 52 31.56	21 51 4.37	A
				MB-A1	34 13 52.89	22 11 54.09	A†	E-S1	34 52 42.97	21 49 56.23	A
A-F1	29 13 27.7	16 11 58.4	S	Ha-D1	34 15 1.8	25 23 47.7	A	F-AH2	34 52 45.69	22 0 3.61	S
A-D1	30 20 35.75	16 51 38.5	A	Ha-II	34 15 21.9	25 42 31.7	A†	F-AH02P	34 52 45.69	22 0 4.43	S
A-H1	30 28 13.26	15 50 46.15	A	Hb-Hart	34 16 38.48	25 55 19.66	A	E-S4	34 52 56.79	21 48 50.34	S
A-J1	30 36 7.66	17 10 2.49	A	Gb-H1	34 16 44.3	24 8 27.4	A	F-AH4	34 52 59.18	22 1 53.5	S†
K-E1	30 37 55.83	15 26 3.01	A†	Ga-B1	34 22 50.64	23 47 52.15	A†	F-AH05P	34 52 59.18	22 1 53.28	S
K-B1	30 42 38.67	15 26 52.18	A	Ha-A1	34 21 24.01	25 40 23.87	A†	E-S6	34 53 1.19	21 50 37.18	A
K-A1	30 48 27.5	16 0 59.89	A	Ga-B1	34 22 50.64	23 47 52.15	A†	F-AN1	34 53 10.23	22 16 35.07	A
A-V1	30 49 44.01	16 34 51.92	S*	Ha-A1	34 21 24.01	25 40 23.87	A†	E-S3	34 53 15.7	21 55 10.4	A
K-A2	30 50 3.21	16 0 32.78	A†	Ha-B1	34 23 44.88	25 41 14.19	A†	E-C1	34 53 16.5	21 25 31.4	A
A-Y1	30 50 48.08	16 39 6.34	S	Ha-B2	34 24 21.17	25 36 32.86	A	E-AG1	34 53 16.56	21 46 45.61	S
A-K1	30 51 30.69	16 35 50.69	A	F-B1	34 24 22.03	22 48 40.22	A	E-H1	34 53 44.1	21 43 15.25	A
A-K2	30 52 23.3	16 36 44.06	S*	Gb-C1	34 24 37.4	24 24 0.9	A	E-M5	34 53 59.78	21 41 40.08	A
K-H1	31 2 20.96	15 55 23.98	A	Ga-X1	34 24 50.57	23 26 12.62	A	F-AZ2	34 54 10.5	22 5 42.6	A
A-A1	31 13 9.19	16 55 16.23	A†	Gb-N1	34 26 10.15	24 39 23.29	A	E-M2	34 54 14	21 39 11.5	A
A-L1	31 18 4.28	16 45 14.05	A	Gb-Gem	34 29 3	24 14 36	A†	E-H2	34 54 16.03	21 42 57.06	S
A-II	31 18 57.33	16 22 50.18	A	Ha-J1	34 30 18.65	25 9 7.61	A*	F-AR3	34 54 43.01	22 3 22.62	A
A-U1	31 38 50.14	16 30 23.31	A	Ga-H1	34 31 3.96	23 45 46.13	A	E-M1	34 54 47.98	21 38 12.33	A
K-D1	31 43 52.65	16 20 13.88	A	Ga-A1	34 33 8.2	23 43 14.67	A†	E-BF01P	34 54 50.25	21 42 46.68	S
Ba-A1	31 52 0.59	17 36 37.25	A†	Ga-A4	34 33 36.07	23 43 17.05	S†	E-M03P	34 54 56.39	21 39 6.38	S
Ba-A2	31 54 30.02	17 41 13.35	A†	Ga-A3	34 33 46.76	23 46 17.55	A†	E-AF1	34 54 57.9	21 57 17.52	A
A-C2	32 19 55.4	16 49 25.27	A	Ga-A2	34 34 26.9	23 45 37.5	A†	E-BF1	34 55 0.55	21 43 21.11	S
A-C1	32 30 29.53	16 53 29.97	A	Ga-G1	34 34 39.35	23 27 0.56	A†	E-MO1P	34 55 7.01	21 38 7.55	S
A-C3	32 32 43.04	16 47 38.24	A	Ga-G1a	34 34 40.52	23 27 0.75	A†	E-MO2Pa	34 55 8.34	21 38 7.2	S
P-A1	32 41 21.88	17 13 59.27	A	Ga-W1	34 35 38.37	23 15 11.74	A	E-MO2P	34 55 8.69	21 38 7.6	A
P-F1	32 44 52.38	17 24 15.96	A	Ga-Q2	34 36 5.2	23 42 54.5	A	F-AR2	34 55 16	22 5 41.13	S
O-A1	33 9 40.64	16 49 23.46	A**	Gb-Spr	34 37 6.39	24 17 8.52	A†	F-AR01P	34 55 16.81	22 5 41.73	S
C-B1	34 51 59.15	18 23 5.4	A	Ga-Q1	34 37 10	23 46 53.6	A	F-E1	34 55 30.27	22 22 3.22	A
				INDIAN OCEAN - SOUTH AND EAST COAST OF SOUTH AFRICA				E-M3	34 55 45.21	21 38 13.56	A
				(In order of increasing Latitude)				F-AR1	34 56 11.9	22 10 10.2	A
				Name	S.	E.	Status	E-E1	34 56 16.36	21 50 38.19	A*
				Jc-A1	29 27 41.3	31 35 39.7	A†	F-E2	34 56 23.9	22 20 41.4	A
				Jc-B1	29 30 25.3	31 37 28.4	A	F-AV1	34 56 25.8	22 19 17.4	A
								E-AB1	34 56 29.09	21 38 15.83	A
								E-V1	34 56 48.37	21 25 29.09	A
								F-AD1	34 57 31.46	22 5 31.54	S
								F-A11	34 57 44.51	22 12 19.29	A

**ABANDONED AND SUSPENDED WELL HEADS /cont**

Name	S.	E.	Status	Name	S.	E.	Status	Name	S.	E.	Status
E-BR1	34 57 44.58	21 34 58.01	A†	E-BA1	35 9 29.67	21 28 31.19	S	E-G2	35 15 58.01	21 28 21.83	A
F-AD01P	34 57 46.96	22 5 52.14	S	E-BH1	35 9 41.57	21 43 13.12	S	E-G1	35 16 48.03	21 27 40.4	A
E-AP1	34 58 7.65	21 10 31.12	A†	E-CC1	35 9 44.87	21 22 33.96	A	E-CR1	35 19 25.64	21 54 54.21	S
F-BE1	34 58 18.85	22 7 37	S	E-N1	35 10 10.84	21 17 54.39	A	F-F2	35 19 38.25	22 17 50	A
F-A5	34 59 1.15	22 11 1.14	S	E-AA2	35 10 23.78	21 33 32.73	A	E-BK1	35 21 19.7	21 53 4.7	S
F-AX1	34 59 12.1	22 19 8.45	A	E-AM1	35 10 42.23	21 48 48.23	A*†	E-P2	35 21 48.86	21 23 52.08	A*
F-A2	34 59 13.98	22 12 38.78	S	E-AA1	35 11 8.8	21 35 36.18	S†	E-CB2	35 21 53.25	21 46 47.38	S
F-A4	34 59 39.26	22 16 2.59	A	E-CE1	35 11 9.34	21 19 52.76	S	E-CB1	35 22 25.16	21 47 55.49	S
E-K1	34 59 45.07	21 36 14.8	A*	E-CE2	35 11 25.34	21 20 34.62	S	E-BL1	35 23 19.35	21 59 14.67	A
F-A1	35 0 4.19	22 14 33.9	A†	E-CE5	35 11 29.83	21 18 9.52	S	E-T1	35 24 1.22	21 32 2.57	A
F-A7	35 0 23.89	22 12 1.11	A	E-CE3	35 11 31.88	21 18 34.03	S	F-P2	35 26 1.17	22 4 16.73	A†
E-AS1	35 0 32.01	21 52 50.78	A	E-AR2	35 11 33.22	21 32 17.29	S	E-R1	35 26 25.1	21 39 24.1	A
F-A9	35 0 33.4	22 14 19	A	E-ARO3P	35 11 55.62	21 32 20.06	S	E-P1	35 27 7.6	21 29 14.2	A
F-A8	35 1 1.17	22 18 8.07	A	E-ARO1P	35 11 56.12	21 32 20.7	S	E-D1	35 27 11.99	21 50 34	A
F-A3	35 1 44.7	22 16 38.6	S	E-ARO2P	35 11 56.75	21 32 20.44	S	E-D2	35 28 10.27	21 52 8.68	A
F-AF1	35 3 21.7	22 13 39.4	A	E-AD1	35 11 59.08	21 38 58.25	S†	F-P1	35 28 21.09	22 10 57.58	A†
E-BO1	35 5 5.93	22 2 0.8	A	E-AR1	35 12 13.72	21 32 42.43	S	E-D4	35 28 36.7	21 46 38.2	A
D-A1	35 5 30.87	20 55 7.98	A	E-BD1	35 12 20.44	21 17 49.23	S	E-D3	35 28 45.91	21 56 16.16	A
E-L1	35 6 8.2	21 11 43.46	A	E-BD3	35 12 23.63	21 17 17.46	S	E-O1	35 30 9.4	21 46 3.7	A
E-CN1	35 6 51.1	21 46 36.1	A	E-BD4	35 12 37.27	21 16 36.85	S	E-DQ1	35 31 11.07	21 43 50.34	S*
F-O4	35 6 59.48	22 32 27.49	S	E-CJ1	35 12 43.02	22 1 8.48	A	E-F1	35 31 19.2	21 45 56.1	A
F-O2	35 7 10.99	22 33 33.34	S	E-BD2	35 12 57.57	21 16 4.94	A	F-L2	35 33 48.3	22 13 33.7	A
E-Z1	35 7 37.5	21 23 14.45	A	E-BX1	35 13 21.1	21 25 8.45	A*	F-L1	35 34 17.61	22 13 18.55	A†
F-O3	35 8 15.54	22 33 32.46	S	E-AK1	35 13 34.75	21 12 15.35	A	E-Q1	35 43 20.7	21 45 22.3	A
E-BA3	35 8 34.05	21 28 50.22	S	E-BT5	35 13 37.79	21 31 22.48	S	F-Q1	35 44 41.5	22 13 52.1	A†
E-BW1	35 9 12.04	21 11 25.85	A	E-BT1	35 13 58.64	21 29 56.48	S	E-Q2	35 47 49.9	21 58 59.5	A
E-CA1	35 9 20.09	21 33 34.96	S	E-BT01P	35 13 59.38	21 29 54.55	S				
F-R1	35 9 25.27	22 36 1.98	S†	E-BB1	35 14 15.33	21 41 41.08	S				
F-S1	35 9 29.07	22 41 45.88	S	E-BB2	35 14 17.61	21 41 22.55	S				

**LIST OF LOST EQUIPMENT and ANCHORS (12 to 20 tonnes).**

Name	Object	Lat (S)	Long (E)	Error Radius
K-A3	anchor	30 48 43.2	16 04 11.2	± 200m
A-V1	anchor	30 49 21.58	16 35 23.08	± 20m
K-A2	anchor	30 50 21.4	15 59 56.2	± 200m
K-A2	anchor	30 50 38.2	16 00 50	± 200m
Ga-H1	anchor S3	34 31 34.6	23 45 32.6	± 40m
Ga-W1	anchor	34 35 34.79	23 15 8.21	± 50 m
Ga-W1	anchor	34 35 41.95	23 15 19.66	± 30 m
Ga-Q2	anchor S1	34 36 22.3	23 44 52	± 100m
F-AH3	anchor No.7	34 52 31.83	21 56 37.16	± 200m
F-A Platform	anchor	34 58 14.46	22 09 27.88	± 25m
E-AP1	anchor	34 58 9.54	21 10 16.96	± 10m
F-A12	anchor S1	34 59 45.07	22 09 50.61	± 15m
Hb-H1i	27 ft of 9" drill collars (steel pipe)	34 9 11.54	25 54 17.45	± 20m
ORCA	anchor	35 14.48	21 30.91	± 100m
E-G3	BOP stack (5.5x3.5m)	35 17 29.1	21 30 30	± 15m
E-AJ2	anchor	35 19 35.45	21 58 3.97	± 10m
E-CB1	anchor No.8	35 23 4.7	21 47 37.9	± 50m
E-DQ2	anchor	35 31 37.43	21 42 25.05	± 15m
E-DQ2	anchor	35 31 41.13	21 43 9.67	± 15m
E-DC1	anchor	35 33 55.67	21 46 10.6	± 30m
F-O4	anchor No.3	35 8 21.93	22 32 13.51	± 20m
F-O1	anchor P2 & 1300m chain	35 9 13.6	22 47 14.56	± 10m

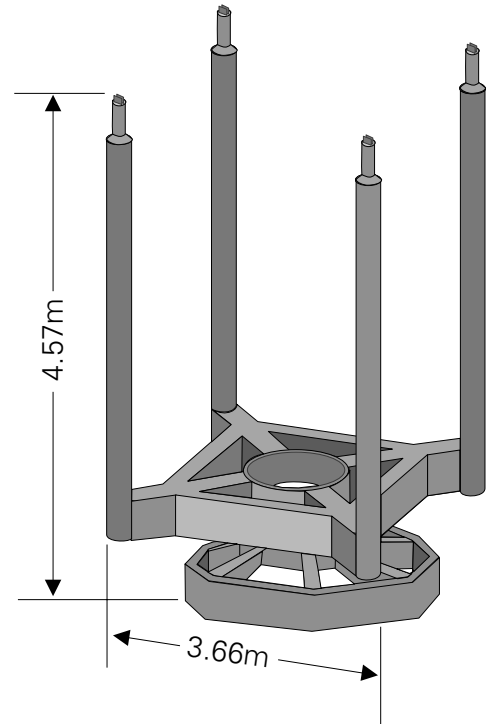

Well Head Structure